

# ME 6005-Process Planning & Cost Estimation

---

## UNIT-I (INTRODUCTION TO PROCESS PLANNING)

### Part-A (2 Marks)

1. What is meant by process planning?
2. What are the factors affect process planning?
3. What are the reasons for process documentation?
4. State the general approaches to process planning?
5. What is CAPP?
6. What are the advantages of CAPP?
7. What is Flow Chart?
8. What are the disadvantages of flow charts?
9. What is decision table?
10. State the benefits of decision table?
11. What are the tools for acquiring documentation knowledge?

### Part-B

1. (i)What is process planning? (8)  
(ii)What are the activities associated with it? (8)
2. Explain the technological framework of process by using a block diagram. (16)
3. List the information required for process planning. (16)
4. What are the factors that influence process planning? (16)
5. Explain in detail the process planning activities. (16)
- 6.(i) Explain the manual approach to process planning. (8)  
(ii) What are advantages and limitations? (8)
- 7.(i) What is meant by CAPP? (4)  
(ii) List out the benefits of CAPP systems. (12)
8. Explain the two approaches commonly used in CAPP system bringing out their advantages and limitations. (16)
9. Compare and contrast the features of a variant and generative CAPP systems. (16)
10. Write short notes on 'tools for developing manufacturing logic and knowledge'.
11. What are the advantages and limitations of using?  
(i) Flow charts (8)  
(ii) Decision tables (8)
12. What factor should be considered while selecting the best process planning system? (16)

## UNIT-II (PROCESS PLANNING ACTIVITIES)

### Part-A (2 Marks)

1. What is meant by Work Study?
2. What is meant by Method Study?
3. What is Process Charts?
4. What is SIMO Charts?
5. What is multiple activity charts?
6. What are therbligs?
7. Where string diagram is used?
8. What is travel chart?
9. What is meant by work measurement?
10. What are the techniques of work measurement?
11. Define performance rating?
12. What is allowance?
13. What do you mean by standard time?
14. How do you calculate the standard time?
15. What is meant by ergonomics?
16. State some application of ergonomics?

### Part-B (16 Marks)

1. Define the terms 'work study', 'method study' and 'work measurement'. Also briefly explain how use of work study leads to higher productivity in a manufacturing unit. (16)
2. List the objectives, purpose, and scope of work study. (16)
  
16. What is meant by ergonomics? Describe the objectives of the study of ergonomics. (16)
17. Discuss the importance of ergonomics by mentioning various areas of application. (16)
18. Write short notes on:
  - (i) Design of man-machine systems, and (8)
  - (ii) Design of working environment. (8)
19. Write a brief about the following:
  - (i) Ergonomic display designs, (6)
  - (ii) Ergonomic design of controls, and (6)
  - (iii) Optimal use of physical efforts. (4)

## UNIT-III (INTRODUCTION TO COST ESTIMATION) Part-A (2 Marks)

1. Define Cost Estimation
2. What are the types of Estimation?
3. What are the methods of Estimation?
4. State the importance of realistic estimates.
5. What is design cost?
6. What is labour cost?
7. What do you mean by overhead cost?
8. Define costing.
9. What are the methods of costing?
10. What is direct cost?

### Part-B (16 Marks)

1. (i)What is cost estimating? (8)
- (ii)State the objectives of cost estimating. (8)
2. List the functions of estimating. (16)
3. Explain the type of cost estimates, that are used in estimating. (16)
4. List and discuss the different methods of cost estimating. (16)
5. List the various data required to make a cost estimate (16).
6. List the various types and sources of data required by the cost estimator. (16).
7. Describe the various constituents of estimation. (16).
8. What shall be the effects of the following on an enterprise?
  - (i) Under estimating, (8)
  - (ii) Over estimating. (8)
9. (i)What do you mean by a realistic estimate? (8)
- (ii) Describe its importance in production. (8)
10. Explain the procedure followed for estimating the cost of an industrial product. (16).
11. Explain in detail the procedure for estimating the cost of water supply fitting in residential building. (16).
12. (i)Define costing or cost accounting (6)
- (ii) Why costing is essential to industrial control? (12).
- 13.(i) What is the purpose of costing? (8)
- (ii) Differentiate between estimating and costing. (8)
- 14 Explain the various methods of costing. (16).

**UNIT-IV**  
**(COST ESTIMATION)**  
**Part-A (2 Marks)**

1. What are the elements of cost?
2. What are the types of cost?
3. What is meant by direct material?
4. What are the types of direct material?
5. State some examples for direct material.
6. What is meant by indirect material?
7. Who are called direct labour?
8. State some examples for direct labour?
9. Who are called indirect labour?
10. What is meant by factory on cost?
11. Defining selling expenses.
12. What is total cost?
13. What is ladder of cost?

**Part-B (16 Marks)**

1. (i) Name the various elements of cost. (8)  
(ii) Explain each element in detail giving suitable examples. (8)
2. (i) Contrast between direct materials and indirect materials. (8)  
(ii) What do you understand by the term 'overhead expenses'? List few items of overhead expenses in a factory. (8)
4. What items of expenditure are included in administrative overheads? (16)
5. Describe in brief:  
(i) Selling expenses, (8)  
(ii) Distribution expenses. (8)
6. List various components of cost (16)
7. Explain the terms prime cost, factory cost, total cost and selling price. Show the relationship between various components of cost with the help of a block diagram. (16)
8. Describe with a block diagram how the selling price of a product is arrived at? (16)
9. Illustrate the relationship between 'elements of cost' and 'components of cost' with the help of a block diagram.
10. Write down the step by step procedure for estimating the direct materials cost ? (16)
11. Briefly explain all the factors to be considered while calculating the time required for a particular job. (16)
12. Define the following terms:  
(i) Set up time, (4)  
(ii) Handling time, (4)  
(iii) Machining time, and , (4)  
(iv) Tear down time. , (4)
13. What are the various time allowances which should be considered for calculating labour cost? (16)
14. Write short notes on:

- (i) Personal allowance, (8)  
(ii) Contingency allowance. (8)  
15. How will you estimate direct labour cost for mass production of an item? (16)  
16.(i) Explain the terms prime cost, factory cost, total cost and selling price. Show the relationship between various components of cost with the help of a block diagram. (8)  
(ii) Allocation by percentage on direct labour cost. (4)  
(iii) Allocation by percentage on direct material cost (4).  
17. When do you prefer allocation of overhead expenses by unit rate? (16)  
18. What do you understand by allocation of overhead expenses? (16)  
19. Describe and compare the various methods of allocation of overhead expenses. (16)  
20. Under what situations, you can use the allocation of overhead expenses by percentage on prime cost method. (16)

### UNIT-V (PRODUCTION COST ESTIMATION)

#### Part-A (2 Marks)

1. Define forging.
2. Differentiate hot forging and cold forging.
3. Contrast smith forging and drop forging.
4. In what ways, press forging and upset forging are different?
5. Define man hour and machine hour rate.
6. What is unit rate?
7. What is scale loss?
8. What are the types of welding?
9. What is the pattern?
10. What is shrinkage allowance?

#### Part-B (16 Marks)

1. An isometric view of a work piece is shown in figure. What will be the weight of the material required to produce it. The density of material is 2.681 gm/cc. Find also the material cost if its rate is Rs.13.60 per kg. All dimensions are in mm. (16)

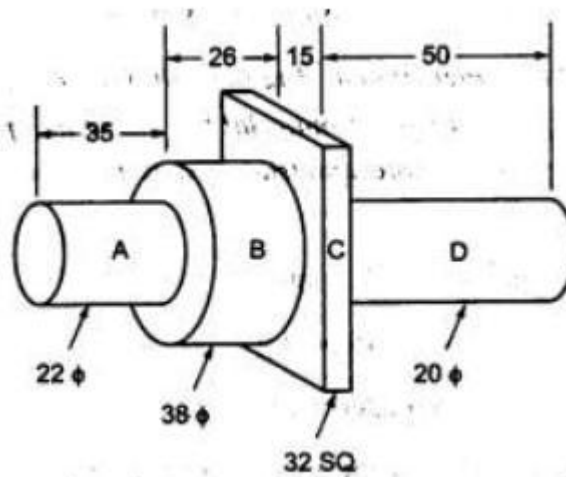

## ME 6005-Process Planning & Cost Estimation

---

2. Estimate the weight of material required for manufacturing 220 pieces of shaft as shown in figure. The shafts are made of mild steel which weighs  $7.87 \text{ gm/cm}^3$  and costs Rs.4.25 per kg. Also calculate the material cost for 220 such shafts. (16)

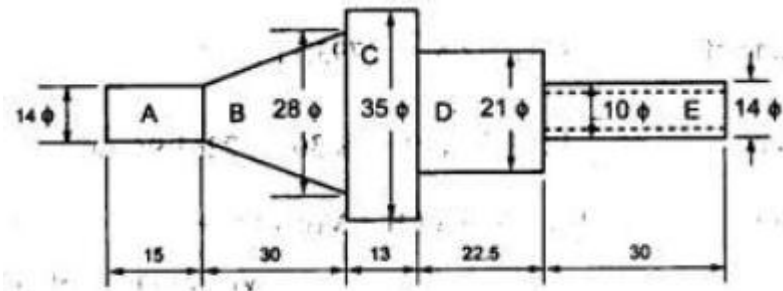

1. For manufacturing a 'milling machine', the expenditure is tabulated in table. (16)

S.No.	Particulars	Expenses in Rupees
1.	Material consumed	46,000
2.	Indirect factory wages	7,000
3.	Director's fees	2,500
4.	Advertising	8,000
5.	Net profit	11,750
6.	Depreciation on sales department's car	900
7.	Printing and stationery	350
8.	Depreciation on plant	4,200
9.	Direct wages	59,000
10.	Factory rent	5,750
11.	Telephone and postal charges	250
12.	Gas and electricity	400
13.	Office salaries	2,000
14.	Office rent	600
15.	Showroom rent	1,200
16.	Salesman's commission	1,850
17.	Sales department car expenses	1,200

*Find out (a) Prime cost, (b) Factory cost, (c) Total cost of production, (d) Cost of sales, and (e) Selling price.*

4. A factory has a capacity to produce 1000 shapers/annum. But at present 'it is working at its 70% capacity. The sales income at this level is Rs.52,50,000. The fixed cost of the factory is Rs.20,00,000 and variable cost per piece is Rs.2500. There is a proposal for mechanization but this will increase the fixed cost by Rs.40,000 and will reduce the variable cost by Rs.500 per unit. Estimate: (a) Whether the proposal is economical?

(b) If a reduction in selling price by Rs.200 per unit make the factory to run at 85 % of its full capacity, would this be a better proposal than the first one. (16)

5. A C.I. factory employees 25 persons It consumes material worth Rs. 35,000 pays workers at the rate of Rs. 5 per hour and incurs total overheads of Rs.20,000. In a particular month (25 days) workers and an overtime of 150 hours and were paid double than the normal rate. Find (i) the total cost, and (ii) the man hour rate of overheads. Assume an 8 hours working days. (16)

6. Two workers complete 20 connecting rods, each weighing 3.5 kg by forging per day. They are paid at the rate of Rs.16 and Rs.14 per day respectively. If the material cost is Rs.7.25/kg and 60% of the direct labour is required to compensate for the factory overheads, estimate the total cost of each rod. (16)

7. A steel component shown in figure is to be drop forged in close impression dies. Estimate the gross weight of the component. The various losses account for 26 % of net weight. Take density as 7.7 gm/cc. (16)

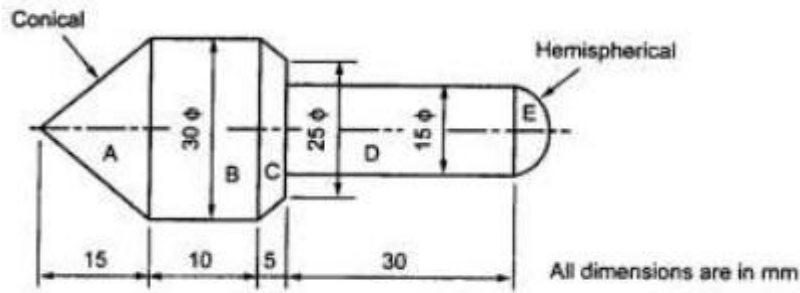

8. An open water tank of size 75 cm X 60 cm X 50 cm is made by gas welding from a 4 mm thick metallic sheet. Estimate the time required for welding a tank. Neglect other factors. (16)

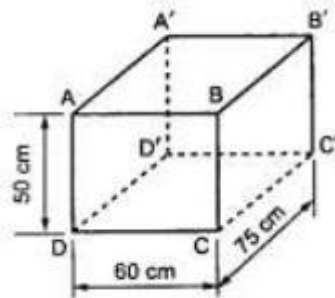

9. Estimate the material cost for welding 2 flat pieces of M.S. 15 X 161 cm size at an angle of 90° by gas welding Neglect edge preparation cost and assume:

Cost O<sub>2</sub> = Rs. 10/m<sup>3</sup> Cost of C<sub>2</sub> H<sub>2</sub> = Rs.. 60/m<sup>2</sup> Density of filler metal = 7 gm/cc Cost of filler metal = Rs. 12/kg filler rod dia = 5 mm filler rod required 4.5 m/m of welding assume O<sub>2</sub> consumption = 0.7 cu.m/hr. C<sub>2</sub>H<sub>2</sub> consumption = 0.5 cu.m/hr. Welding time = 30 min/m of welding.

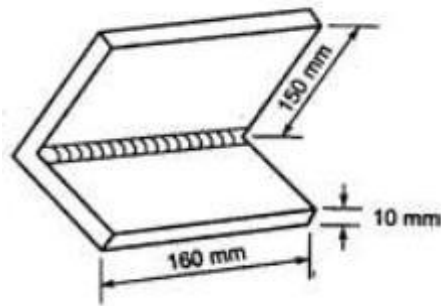

10. An engine flywheel is required to be cast according to drawing shown in figure. (16)



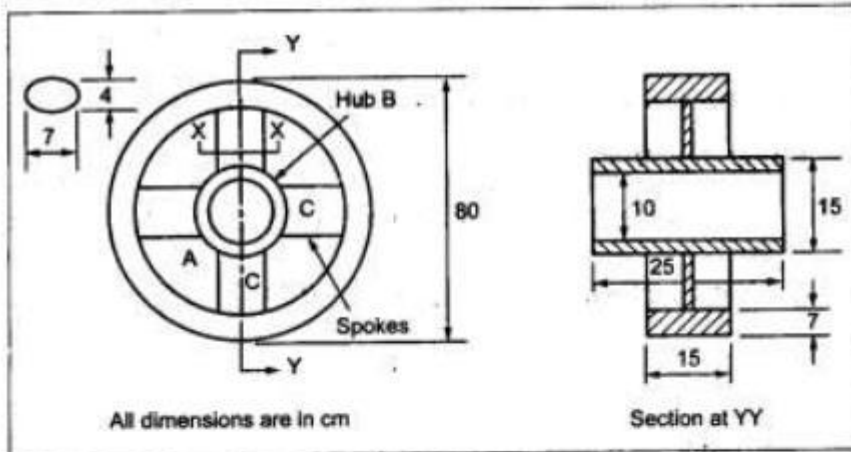

Fig. 10.5.

- (a) Estimate the net weight of the flywheel casting.
- (b) Estimate the selling price of each wheel, given the following data :
- (i) Cost of pattern = Rs. 75 per 500 castings;
  - (ii) Process scrap = 11% of net weight;
  - (iii) Scrap return value = Rs. 0.70 per kg;
  - (iv) Cost of molten metal at furnace spout = Rs. 2 per kg;
  - (v) Administrative overheads = Rs. 6 per hour;
  - (vi) Selling overheads = 25% of production cost;
  - (vii) Profit = 15% of total cost;
  - (viii) Density = 7.2 gm/cc.

Other expenditure detail are :

Unit operation	Time per piece	Labour rate/hour	Shop overheads/hour
Moulding	12 min	Rs. 2.75	Rs. 4.50
Pouring	6 min	Rs. 2.50	Rs. 3.50
Shot blasting	5 min	Rs. 2.60	Rs. 4.00
Fettling	6 min	Rs. 2.40	Rs. 3.25

11. 20 numbers of gun metal bevel gear blank shown in figure are to be cast in the factory from the planner supplied by the customer Estimate the selling price of each piece from the following data.

- (i) Cost of molten gun metal= Rs.9.20 per kg. (3)
- (ii) Scrap return value = Rs.s 5.00 per kg. (3)
- (iii) Process scrap = 10 % net weight of casting (3).

- (iv) Administrative overheads=Rs.3.50 per kg (3).
- (v) Profit=15% of manufacturing cost. (2)
- (vi) Density of gun metal = 8.73 gm/cc. (2)

